



# INSTRUCTION BULLETIN

No. 9004952  
Machine: S30/S30 X4/  
S30 XP  
Published: 08-2010  
Rev. 01

**NOTE: DO NOT DISCARD the Parts List from the Instruction Bulletin. Place the Parts List in the appropriate place in the machine manual for future reference. Retaining the Parts List will make it easier to reorder individual parts and will save the cost of ordering an entire kit.**

*NOTE: Numbers in parenthesis ( ) are reference numbers for parts listed in Bill of Materials.*

Installation instructions for **kit number 9003865**

## SYNOPSIS:

This kit contains the parts needed to install an inside light kit (flashing light, backup alarm, and backup light) on S30, S30 XP, and S30 X4 machines (serial numbers 000000-002099)  
Please follow step-by-step instructions.

## SPECIAL TOOLS / CONSIDERATIONS: NONE

(Estimated time to complete: 2 hours)

## PREPARATION:

1. Empty the hopper. Refer to the Operators Manual for instructions and safety information.



**WARNING: Lift arm pinch point. Stay clear of hopper lift arms.**

**FOR SAFETY: When using machine, make sure adequate clearance is available before raising hopper.**

2. Park the machine on a clean level surface, raise the hopper, engage the hopper support, turn off the machine, remove the key, and set the parking brake.



**WARNING: Raised hopper may fall. Engage hopper support bar.**

**FOR SAFETY: Before leaving or servicing machine, stop on level surface, turn off machine, and remove key.**

3. Disconnect the battery cables from the battery.

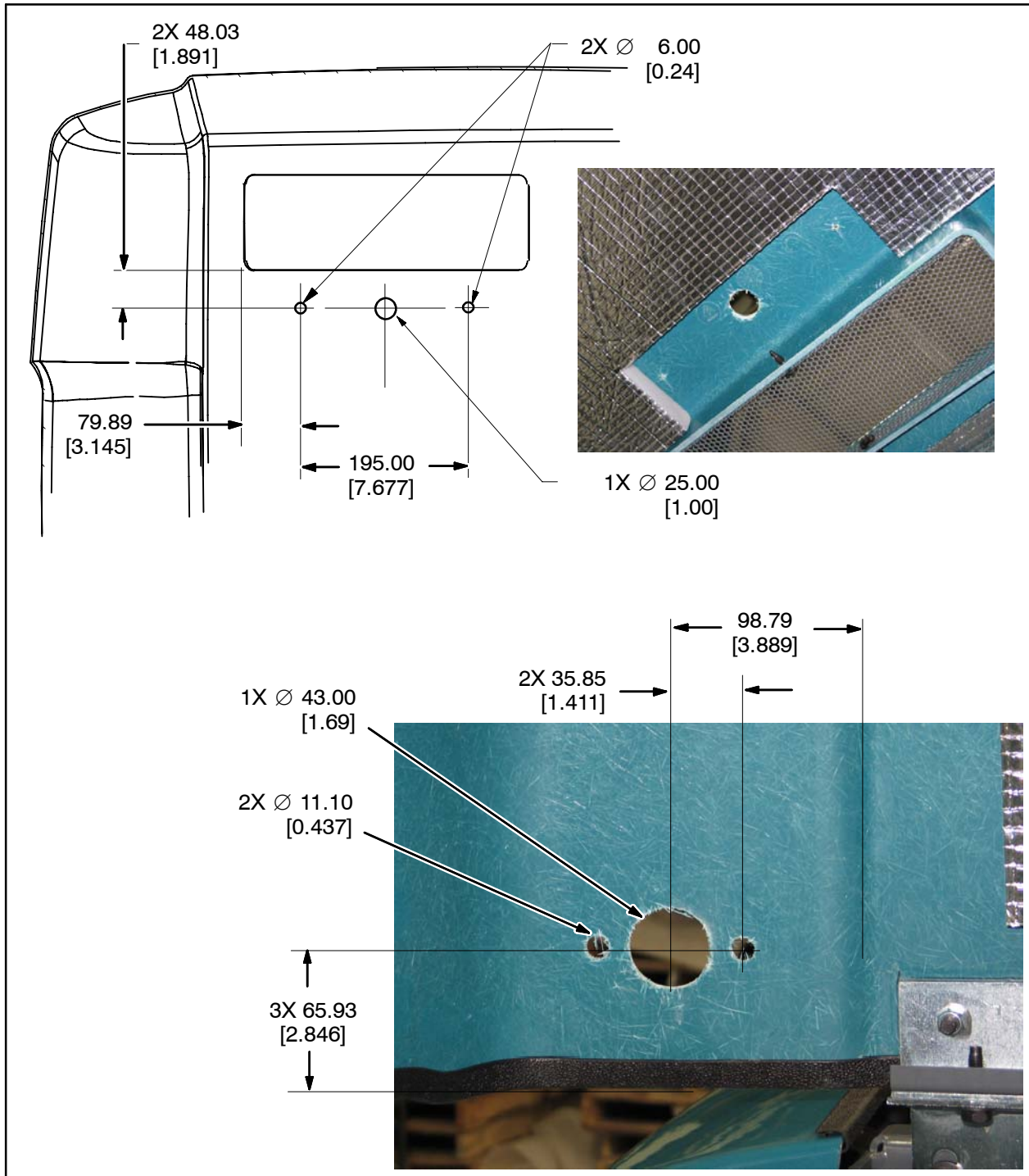


**WARNING: Always disconnect battery cables from machine before working on electrical components.**

4. Open the rear engine cover, side shroud, and the top cover.

**INSTALLATION:**

1. Drill three appropriately sized holes for the white light (2) into the rear engine cover. Refer to Fig. 1 for sizes and locations.
2. Drill three appropriately sized holes for the light bracket (17) into the rear engine cover. Refer to Fig. 1 for sizes and locations.



**FIG. 1**

- Machines without overhead guards only:** Use two pan screws (16), two washers (5), and two hex nuts (3) to install the light (20) onto the light bracket (17). Refer to Fig. 2.

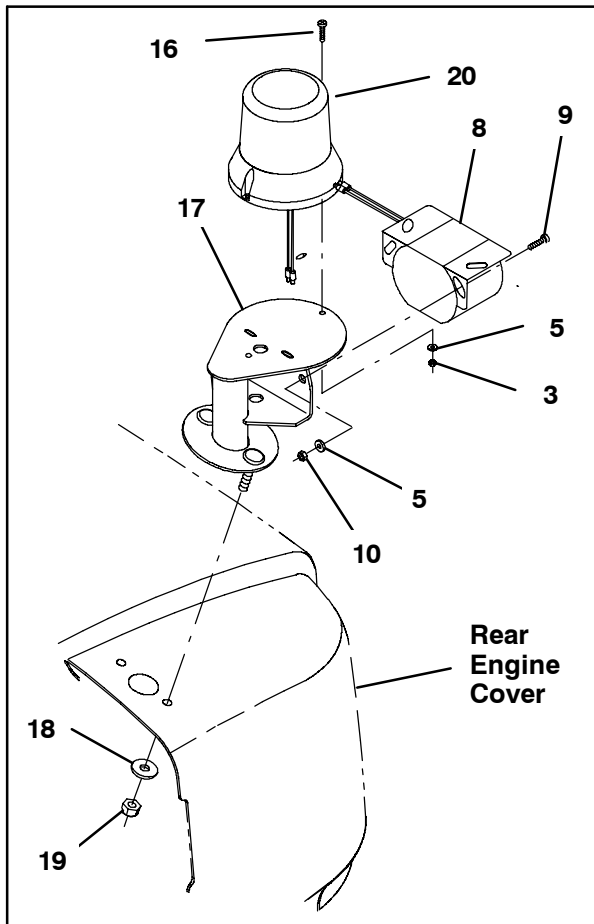


FIG. 2

- Use two pan screws (9), two washers (5), and two hex nuts (10) to install the backup alarm (8) onto the light bracket (17). Refer to Fig. 2.
- Route the cable from the backup alarm (8) (and the light (20) if light is installed on the light bracket (17)) through the hole in the bracket and the larger hole in the rear engine cover. Refer to Fig. 2 and Fig. 3.

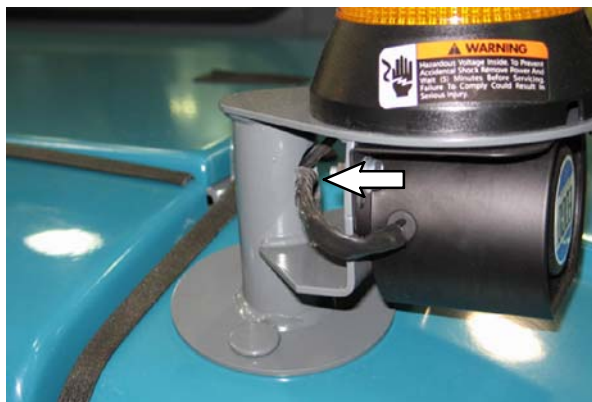


FIG. 3

- Use two hex nuts (19) and two washers (18) to install the light bracket (17) and cable clamp (22) onto the rear engine cover. Refer to Fig. 2 and Fig. 4.

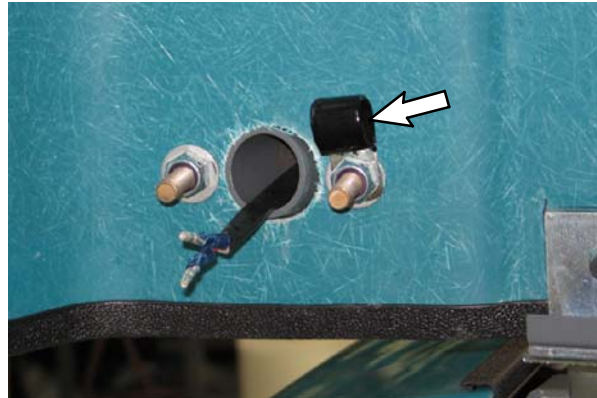


FIG. 4

- If installing light (2) onto overhead guard:** Use two pan screws (16), two washers (5), and two hex nuts (3) to install the light (20) onto the overhead guard. Refer to Fig. 5.

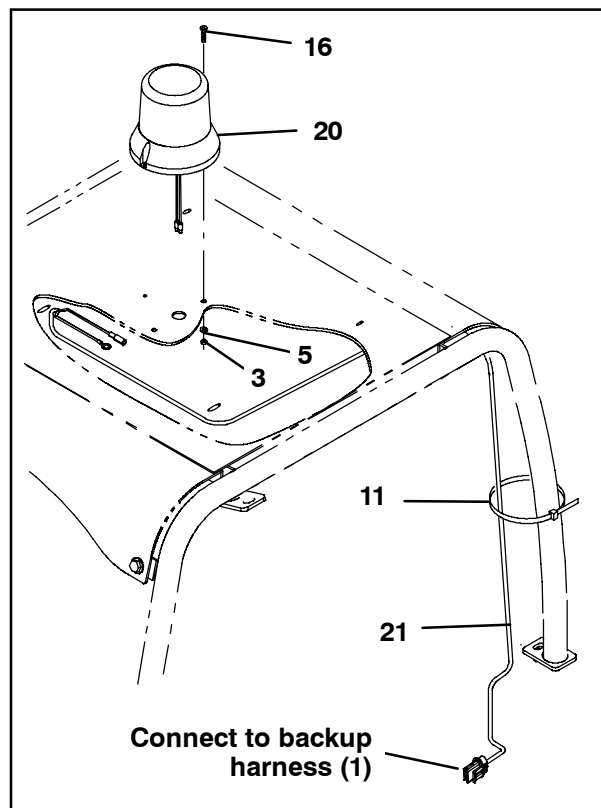
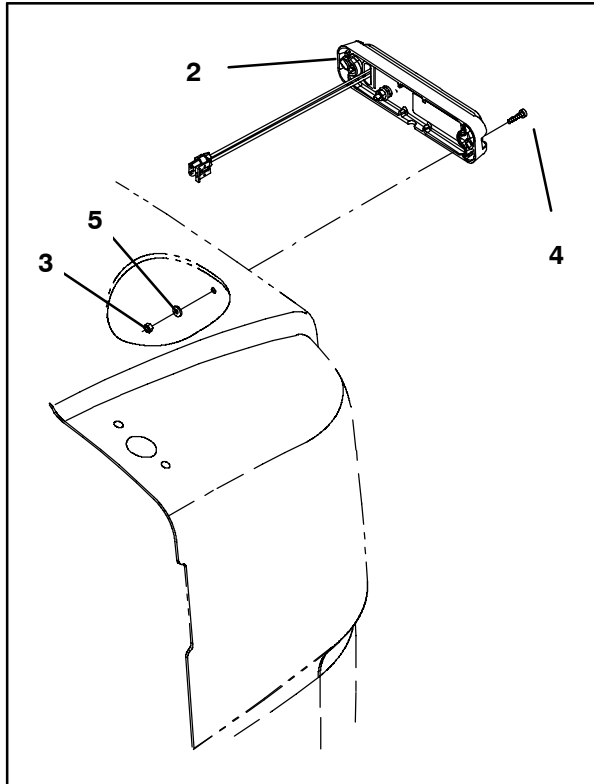


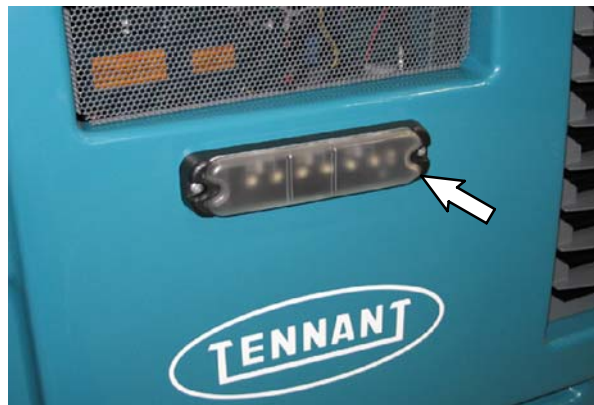
FIG. 5

- Connect the overhead light harness (21) to the light (20). Refer to Fig. 5.
- Route the overhead light harness (21) down the rear leg of the overhead guard and into the engine compartment. Refer to Fig. 5 and Fig. 15.

10. Use cable ties (11) to secure the overhead light harness (21) to the rear leg of the overhead guard. Refer to Fig. 5.
11. Route the back light (2) cable through the hole in the rear engine cover and use two pan screws (4), two washers (5), and two hex nuts (3) to install the light onto the cover. Refer to Fig. 6 and Fig. 7.

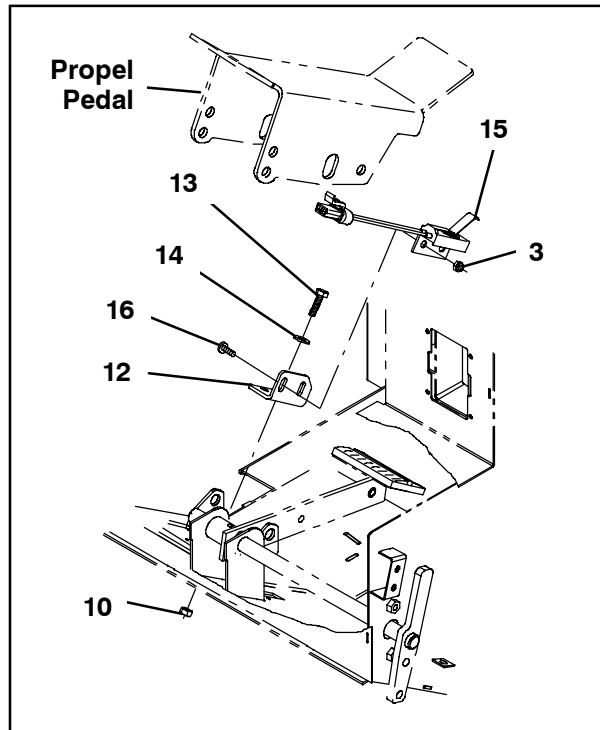


**FIG. 6**



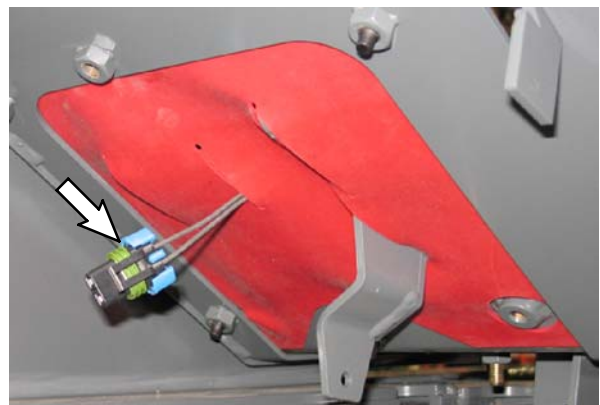
**FIG. 7**

12. If necessary, remove the propel pedal from the machine. Set all mounting hardware aside. Refer to Fig. 8.
13. Use two hex nuts (3) and two pan screws (16) to install the switch (15) onto the reverse switch bracket (12). Refer to Fig. 8.



**FIG. 8**

14. Use two hex screws (13), two washers (14), and two hex nuts (10) to install the reverse switch bracket (12) onto the machine. Refer to Fig. 8.
15. Route the switch (15) cable down through the rubber gasket in the propel pedal access panel. Refer to Fig. 9.



**FIG. 9**

16. Reinstall the propel pedal.



17. Cut the cable ties from the bundled section of the main wire harness and connect the the switch (15) cable to the main wire harness. Refer to the cable labels and Fig. 10, Fig. 16 and Fig. 17 for connection locations.

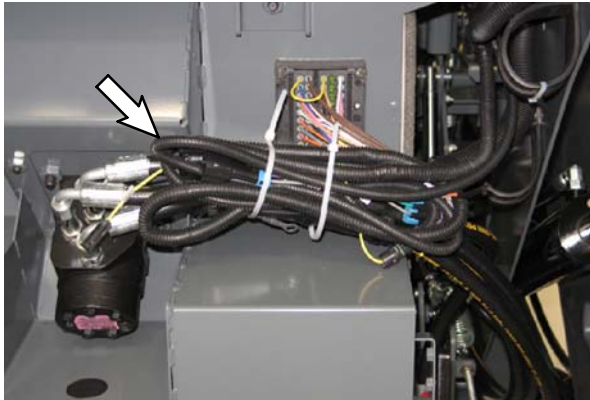


FIG. 10

18. Use two pan screws (7), two washers (5), and two hex nuts (3) to install the flasher (6) onto the engine control bracket. Refer to Fig. 11.

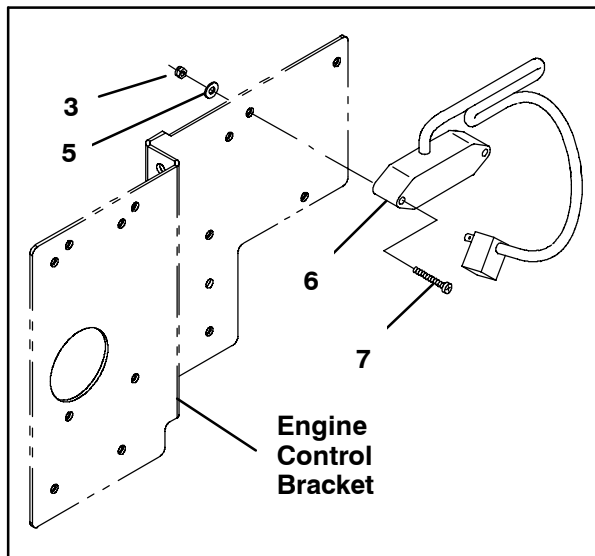


FIG. 11

19. **Machines with overhead guards only:** Route the overhead light harness (21) to the main wire harness and connect the overhead light harness to the main wire harness. Refer to the cable labels and Fig. 5, Fig. 12, Fig. 16, and Fig. 17 for routing/connection locations.

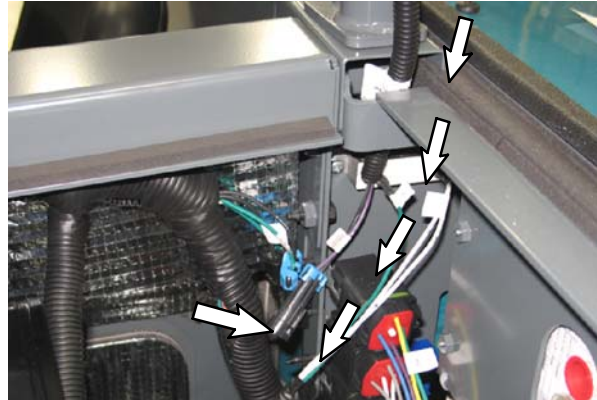


FIG. 12

20. **Machines without overhead guards only:** Connect the backup harness (1) to the two main wire harness connectors located near the engine control bracket. Refer to the labels on each harness and Fig. 13, Fig. 16, and Fig. 17 for connection locations.

**Machines with overhead guards only:** Connect the backup harness (1) to the remaining main wire harness connector located near the engine control bracket. Refer to the labels on each harness and Fig. 16 and Fig. 17 for connection locations.

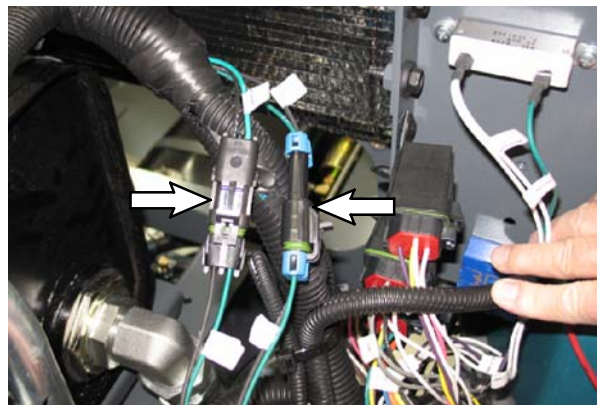
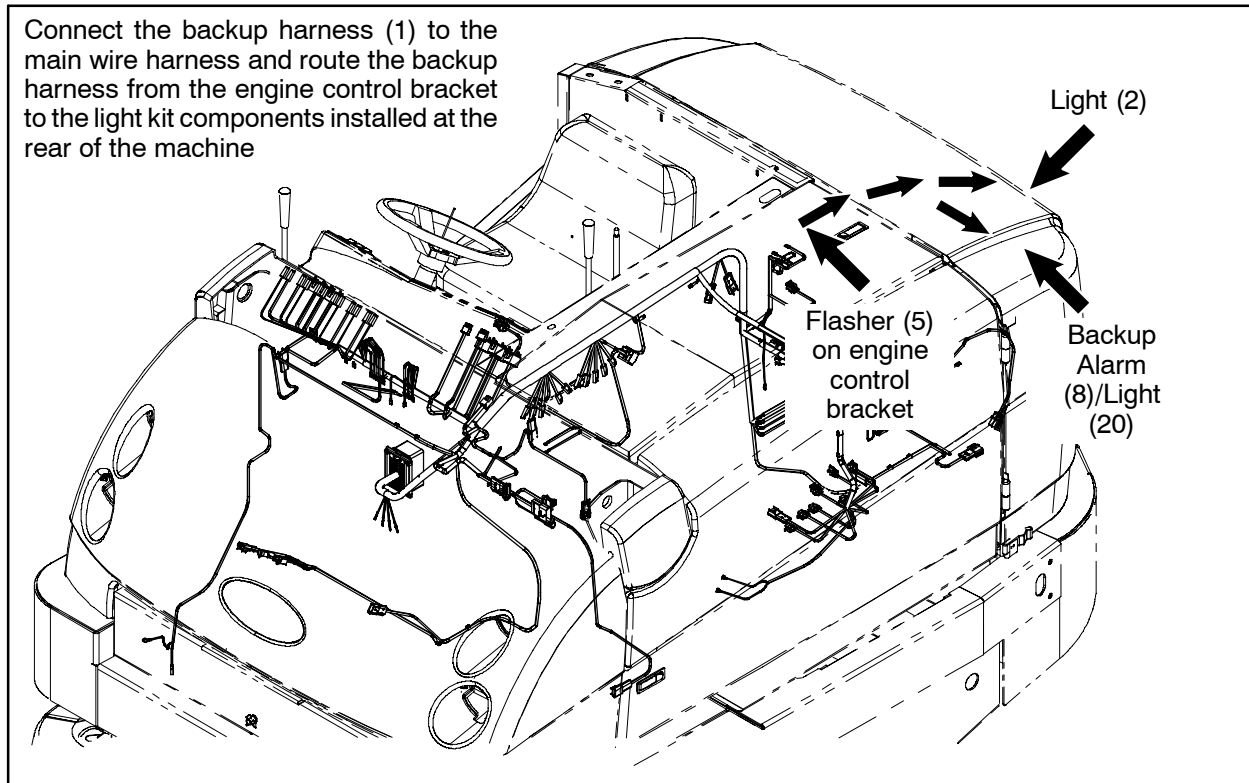


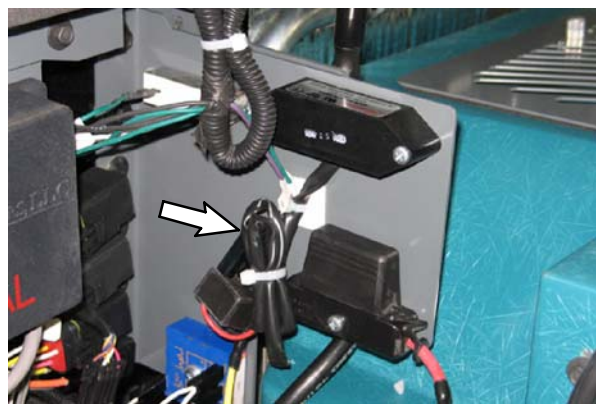
FIG. 13

21. Connect the backup harness (1) to the flasher (6). Refer to the cable labels and Fig. 11, Fig. 14, Fig. 16 and Fig. 17 for connection locations.



**FIG. 14**

22. Neatly bundle any excess backup harness (1) lead connected to the flasher (6) and secure the bundle with a cable tie (11). Refer to Fig. 15.



**FIG. 15**

23. Route the backup harness (1), through the cable clamp (22), to the backup alarm (8) (and light (20) if light is installed on bracket) and connect the component(s) to the harness. Refer to the cable labels and Fig. 14, Fig. 16, and Fig. 17 for routing/connection locations.

24. Route the backup harness (1) to the back light (2) and connect the harness to the light. Refer to the cable labels and Fig. 12, Fig. 14, and Fig. 15, and Fig. 17 for the routing/connection location.

25. Reconnect the battery cables to the battery.

26. Start and test the machine to ensure the lights and alarm operate when the machine is in reverse.

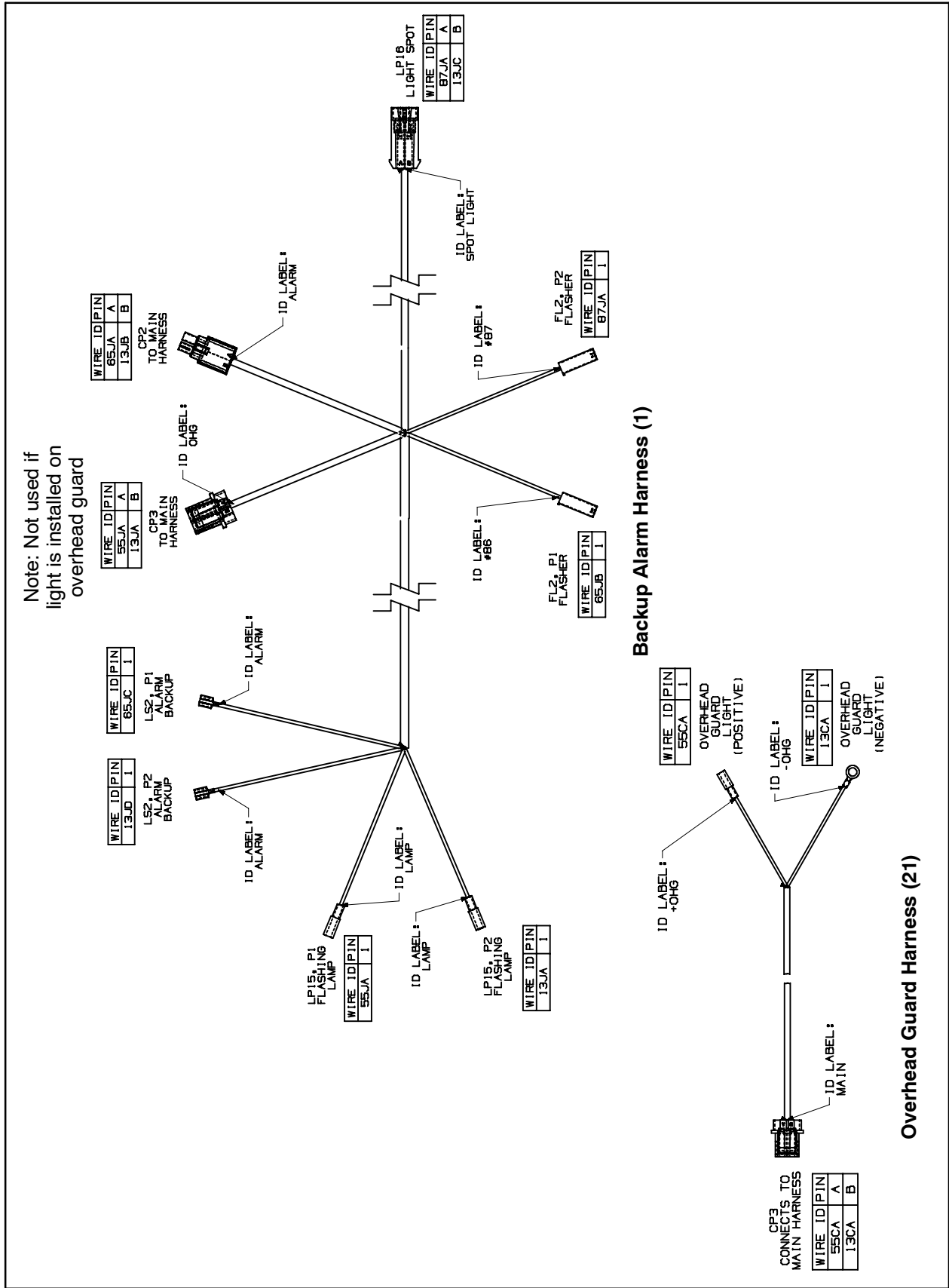


FIG. 16





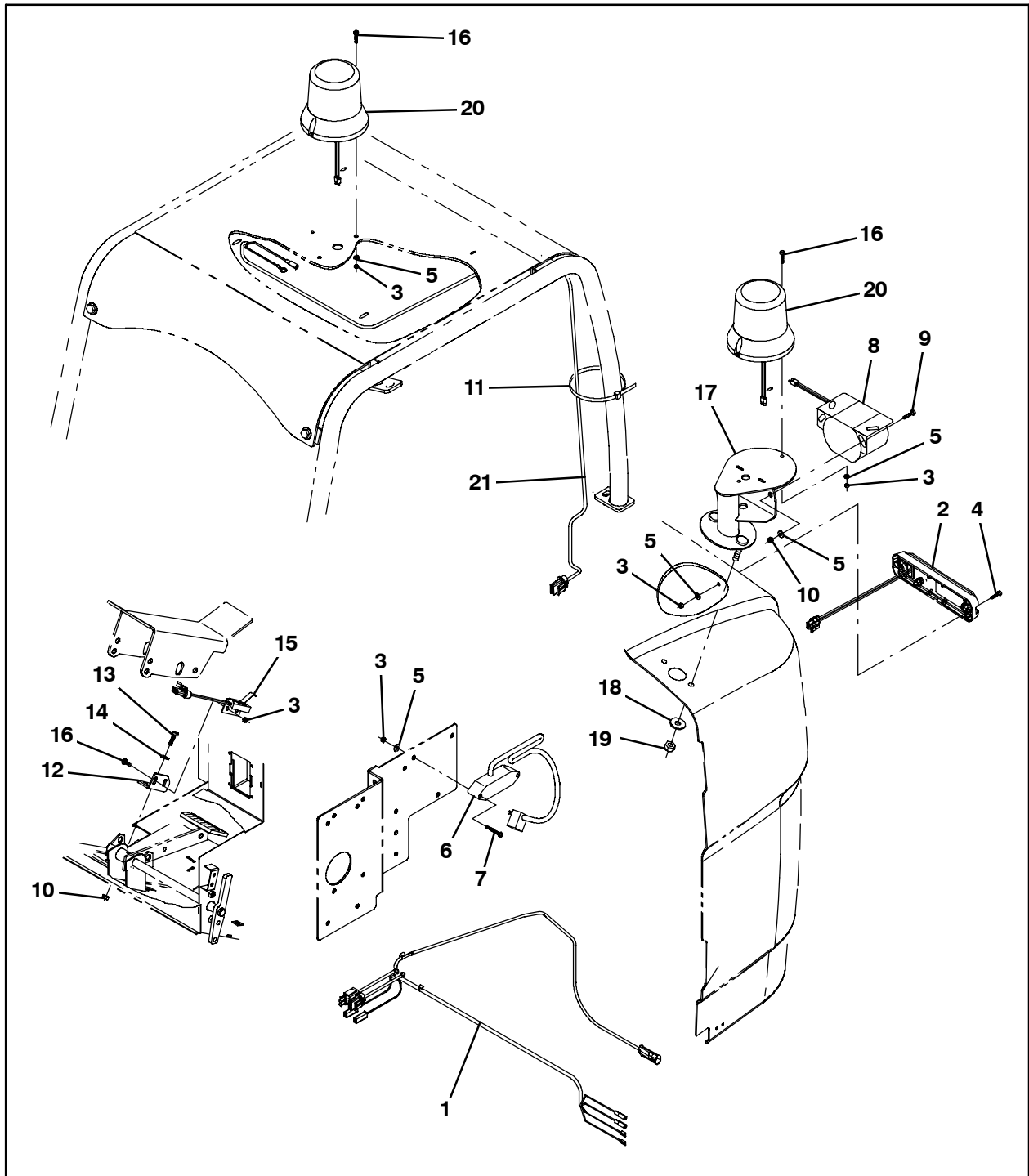


FIG. 18

**Bill of Materials for Light Kit, Inside, CI [S30] - 9003865**

	<b>Ref.</b>	<b>Tennant Part No.</b>	<b>Description</b>	<b>Qty.</b>
▽		9003865	Light Kit, Inside, CI [S30]	1
▲	1	1034191	Harness, Backup, Rev [S30]	1
▲	2	1036173	Light, Led, White, 12-24VDC	1
▲	3	06549	Nut, Hex, Lock, M5 X 0.80, NI	8
▲	4	06935	Screw, Pan, Phl, M5 X 0.80 X 25, 4.8	2
▲	5	19066	Washer, Flat, 10	8
▲	6	1036985	Flasher, 12-80VDC, 2a	1
▲	7	06938	Screw, Pan, Phl, M5 X 0.80 X 40, 4.8	2
▲	8	61923	Alarm, Backup, 12-24VDC 82-107dBa	1
▲	9	09145	Screw, Pan, Phl, M6 X 1.00 X 16, 4.8	2
▲	10	07785	Nut, Hex, Std, M6 X 1.00, SS	4
▲	11	49266	Tie, Cable, Nyl, 07.3l .19w 1.8 Max D	4
▲	12	1036995	Bracket, Switch, Reverse	1
▲	13	08716	Screw, Hex, M6 X 1.00 X 20, SS	2
▲	14	32483	Washer, Flat, 0.25, SAE	2
▲	15	1039735	Switch, Snap, 15a NO	1
▲	16	06933	Screw, Pan, Phl, M5 X 0.80 X 16, 4.8	4
▲	17	1036111	Bracket Wldt, Light, Flsh	1
▲	18	13248	Washer, Flat, 0.40b 1.12d .12, Stl, Pl	2
▲	19	41430	Nut, Hex, Lock, M10 X 1.5, NL	2
▲	20	1017248	Light, Flash, Amb, 12-48VDC	1
▲	21	1030973	Harness, OHG [S30]	1
▲	22	82829	Clamp, Cable, Stl, 0.63d X 0.75w, 1 Hole	1

TENNANT COMPANY  
P. O. Box 1452  
Minneapolis, MN 55440-1452